



Detectors



Compact, stable and dynamic performance

The core of the HELIOS® monitoring system is a new family of detectors that uses the latest in solid state technology to achieve compact, stable and dynamic performance. Our entire electronics package fits in the detector head and a USB “dongle” interface...there are no rack mounted components. In addition, the HELIOS detector package has internal pre-amplification, stabilization and provides linear outputs over at least 7 orders of dynamic range. Sensitivity has been enhanced to its maximum levels in both detector active areas and pick-up electronics with exceptionally quiet noise and drift levels. We offer (4) different modular packages to suit sensitivity and spectral ranges: Silicon, Low-Level Silicon, InGaAs and Extended InGaAs.

Features

- Greater than (7) orders of linear dynamic range
- One packaged solution with USB connection
- SD-S1 Standard detector on all systems and families
- Extremely stable even without TE cooling



SD-S1 and SD-L1 Silicon Detectors (0.32 - 1.10 μm)

Large active areas, exceptional electronic and pre-amplifier design and temporal stabilization offer outstanding performance and sensitivity. The silicon detectors are not TE cooled but feature extremely stable output over a wide range of temperatures and light levels. The S1 is the standard detector on most of the HELIOS systems. The L1 offers extremely low light level capability for our L-Family and other optional low light applications.

SD-S1 Wedge, Standard Filter and Shutter Accessories

Mounted on every HELIOS 0.5" detector port with the SD-S1 is a standard stack of three valuable accessories: a detector "wedge" that places the detector FOV at the back center of the sphere, a 3-position filter holder and a 3-position shutter/pinhole assembly.

Wedge: The sphere's radiance is most linearly tracked if the detector FOV and the DUT FOV are co-located at the back center of the sphere – LabSphere uses our wedge assembly to locate the FOV.

Filter Holder: The filter holder allows up to (3) different 0.5" (up to 0.250" thick) filters to be mounted and manually selected by the user.

Shutter: The manual shutter assembly allows the detector to be put into a dark state without turning off the sphere sources and also provides a replaceable pinhole option to attenuate signal to the detector should saturation occur. These come with each HELIOS SD-S1 detector.

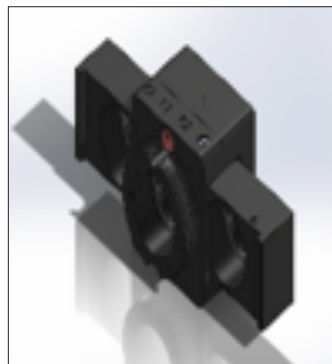

SD-S1 Specifications

Absorber:	Silicon
Sampling Frequency:	6 Hz
Spectral Range:	320 to 1100 nm
Peak Sensitivity:	980 nm
Maximum Power, Typical:	100 μ W [36 mW/cm ²] (@ 1064 nm)
Minimum Power:	0.9 pW @ 320-1100 nm (10 x NEP)
Typical Detector Saturation Current:	6.3 mA/cm ²
Resolution:	1 fW
Temperature Offset Dependence:	1 pA/°C
Aperture:	Ø 10 mm
Active Area:	0.9 cm ² (5.3 mm radius)
Response Time: (10-90%)	4.0 sec
Noise:	0.03 pA RMS on 1 sec with 5 sec moving average; 0.06 pA RMS on 5 sec with 5 sec moving average
Noise Equivalent Drift Over 2 Minutes:	0.09 pW @ 320-1100 nm RMS on 1 sec with 5 sec moving avg.
Sensitivity, Typical:	0.37 A/W @ 320-1100 nm
Dimensions:	Standard Housing 27.4 mm x 38.1 mm diameter
Weight:	130 g

SD-L1 Specifications

Absorber:	Silicon
Sampling Frequency:	0.2 Hz
Spectral Range:	320 to 1100 nm
Peak Sensitivity:	980 nm
Maximum Power, Typical:	100 μ W [36 mW/cm ²] (@ 1064 nm)
Minimum Power:	1.2 pW @ 320-1100 nm (10 x NEP)
Typical Detector Saturation Current:	6.3 mA/cm ²
Resolution:	1 fW
Temperature Offset Dependence:	1 pA/°C
Aperture:	Ø 10 mm
Active Area:	0.9 cm ² (10.6 mm diameter)
Response Time: (10-90%)	4.0 sec
Noise:	0.07 pA RMS on 10 sec with 5 sec moving average 0.12 pA p-p over 2 minutes
Noise Equivalent Drift Over 2 Minutes:	0.12 pW over 2 minutes
Sensitivity, Typical:	0.37 A/W @ 320-1100 nm
Dimensions:	Standard Housing 27.4 mm x 38.1 mm diameter
Weight:	130 g

SD-S1 and SD-L1 Dimensional Drawings

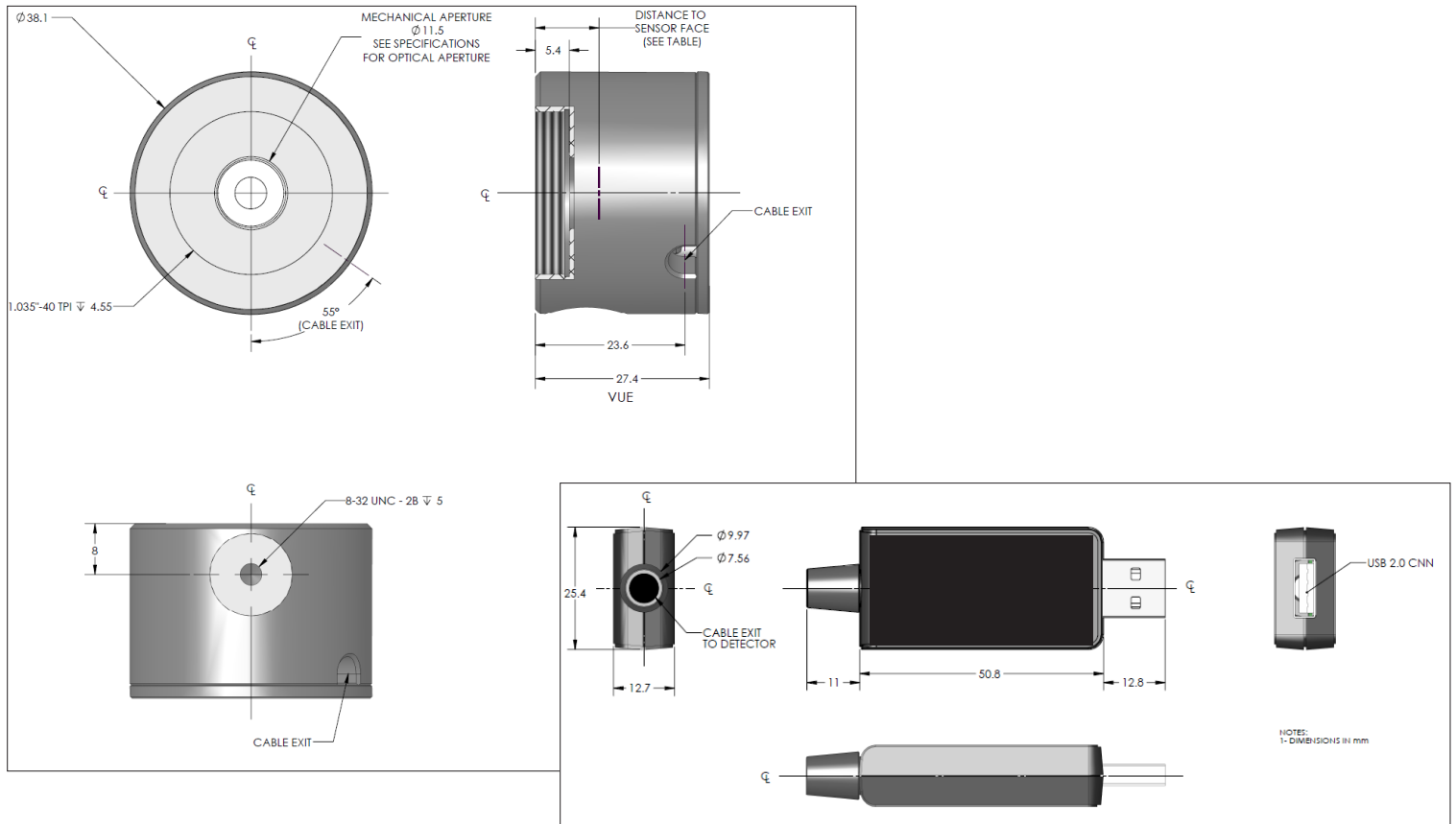



THE ID-T1 INGAAS and EID-T1 Extended-INGAAS Detectors

(900 - 1700 nm and 700 - 2600 nm)

These optional detectors take your monitoring ability into the NIR and SWIR regions. Labsphere has created an outstanding package of TE Coolers and matched detector heads that offer unparalleled signal range and sensitivity. The cooler controller and detector come as a set with the heads being slightly larger for the TE heat sink, but the USB Dongle interface is similar for the InGaAs products as it is for the silicon.

Features

- One packaged solution with USB connection
- 3-stage TE Cooler included – USB connection required (2nd USB)
- Can mount to wedge/pinhole/shutter or direct mount

ID-T1 Specifications

Absorber:	J22TE2-66C-R03M (1.7 μ m Cutoff 3-stage TE Cooled InGaAs Detectors)
Sampling Frequency:	0.2 Hz
Spectral Range:	900 - 1700 nm
Peak Sensitivity:	1500 nm
Maximum Power, Typical:	0.8 mW at peak
Minimum Power:	0.08 nW at peak
Typical Detector Saturation Current:	0.8 mW at peak
Resolution:	<0.1 pA
Operating Temperature:	-40°C
Aperture:	\varnothing 10 mm
Active Area:	0.07 cm ² (3 mm diameter)
Response Time: (10-90%)	4.0 sec
Noise:	<1 pA
Noise Equivalent Drift Over 2 Minutes:	40 pA
Sensitivity, Typical:	0.95 A/W at peak
TE Controller:	TC-1 TE Controller (Required)
Dimensions:	41.2 mm (D) X 56.5 mm (H) (with connector 63.1 mm (L))
Weight:	200 g

EID-T1 Specifications

Absorber:	J23TE3-66C-R03M-2.6 (2.6 μ m Cutoff 3-stage TE Cooled extended InGaAs Detectors)
Sampling Frequency:	0.2 Hz
Spectral Range:	700 - 2600 nm
Peak Sensitivity:	2200 nm
Maximum Power, Typical:	0.8 mW at peak
Minimum Power:	0.8 nW at peak
Typical Detector Saturation Current:	0.8 mW at peak
Resolution:	<0.1 pA
Operating Temperature:	-50°C
Aperture:	\varnothing 10 mm
Active Area:	0.07 cm ² (3 mm diameter)
Response Time: (10-90%)	4.0 sec
Noise: (current)	<10 pA
Noise Equivalent Drift Over 2 Minutes:	400 pA
Sensitivity, Typical:	1.2 A/W @ peak
TE Controller:	TC-1 TE Controller (Required)
Dimensions:	41.2 mm (D) X 56.5 mm (H) (with connector 63.1 mm (L))
Weight:	200 g

ID-T1 and EID-T1 Dimensional Drawings

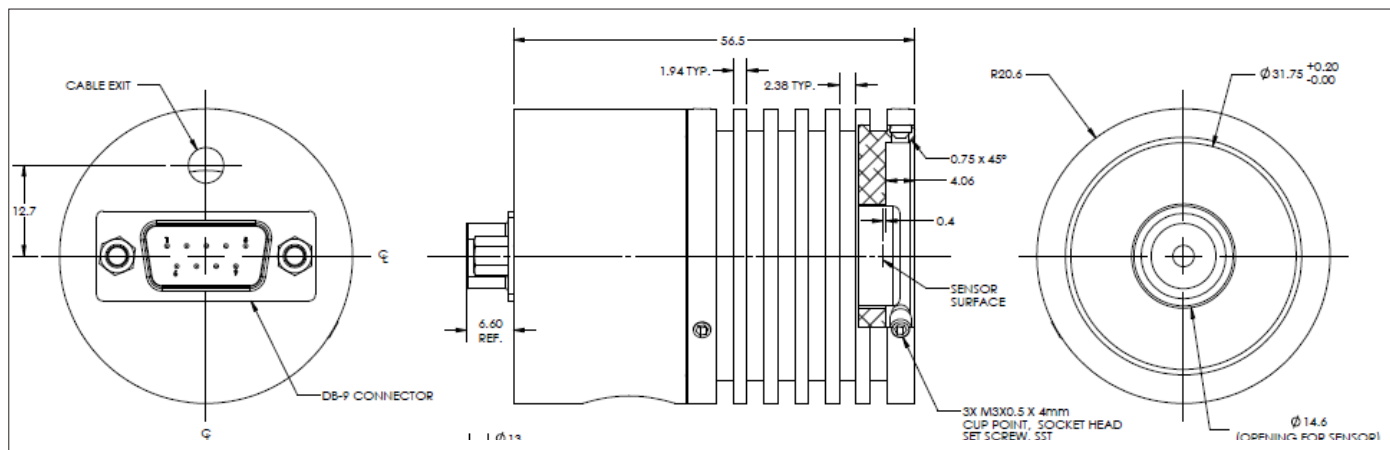

Advancing the Technology of Light: Measure. Create. Reflect.

sales@labsphere.com

www.labsphere.com

© 2019 Labsphere, Inc. All Rights Reserved
PB-14027-000 Rev 03

EID & ID TE Controller Specifications

Model Number

TC-1

Temperature Controller Range:

Software programmable temperature set point ° from -60°C to 20°C in 0.1°C increments

Stability:

±0.5°C (PTP over 10 minutes after stabilization period of 15 minutes)

Dimensions:

P-Link Enclosure: 286 mm(W) x 233 mm(H) x 43 mm(D)

DC Power Requirements:

12VDC External Supply Required (Provided by Labsphere)

TC-1 Connection to Detector:

DB-9

TC-1 Connection to Computer:

USB 2.0

TE Controller and Detector Wiring

